

Panelsource

ENGINE & GENERATOR CONTROLS

The P1, P2 & P3 Series

Typical Application

The P1, P2 & P3 lines of generator control panels are designed for use where generator output monitoring is required. The panel is usually mounted on the generator connection box for local monitoring.

Description

The control panel is housed in a compact, NEMA 1 equivalent, ABS industrial grade plastic enclosure. Models can be setup for single or three phase and 120 through 480 volt applications.

Features

- ⇒ Various sizes available to fit most installation requirements.
- ⇒ Corrosion resistant & shock-proof ABS enclosure.
- ⇒ 2¹/₂" or 3¹/₂" industrial meters.
- ⇒ Rotary volts/amps selector switch.
- ⇒ Internal color-coded and numbered wiring for ease of connection.
- ⇒ Current transformers supplied with assembly.
- ⇒ Vibration isolators for generator top-mount installation.
- ⇒ Fuse block and fuses for instruments.
- ⇒ Corrosion resistant hardware used throughout assembly.

The P4 Series

Typical Application

The P4 line of generator control panels is designed to accommodate generator and engine instrumentation as well as optional protective devices.

Description

The control panel is typically configured to monitor engine oil pressure, engine water temperature, engine hours and battery voltage, in addition to the normal generator functions. Due to the cabinet size, other components may be installed to offer engine protection. Models can be setup for manual or auto start, single or three phase, and 120 through 480 volt applications.

Features

- ⇒ Corrosion resistant & shock-proof ABS enclosure.
- ⇒ Base model includes provision for engine instrumentation and mini-hourmeter.
- ⇒ Enclosure allows installation of engine protection modules.
- ⇒ Variety of options allow for complete custom system.
- ⇒ Optional gauge package features VDO Instruments

The P9 Series

Typical Application

The P9 line of generator control panels offers the user a complete automatic system for unmanned operation of generator sets. Both start and stop functions are controlled by proven microprocessor based technology.

Description

The control panel offers generator and engine instrumentation while incorporating automatic operation and engine safety features common to the industry.

Features

- ⇒ Corrosion resistant & shock-proof ABS enclosure.
- ⇒ Microprocessor-based engine/generator controller includes engine and generator instrumentation.
- ⇒ J1939 compatibility.
- ⇒ Available with RS232 and RS485 remote communications.
- ⇒ Fully user-programmable for ease of installation on various applications.
- ⇒ Available with features that meet UL/CSA and NFPA110 requirements.
- ⇒ Supplied with reliable senders and auxiliary relays.

How to Order by Panelsource™ Part Number

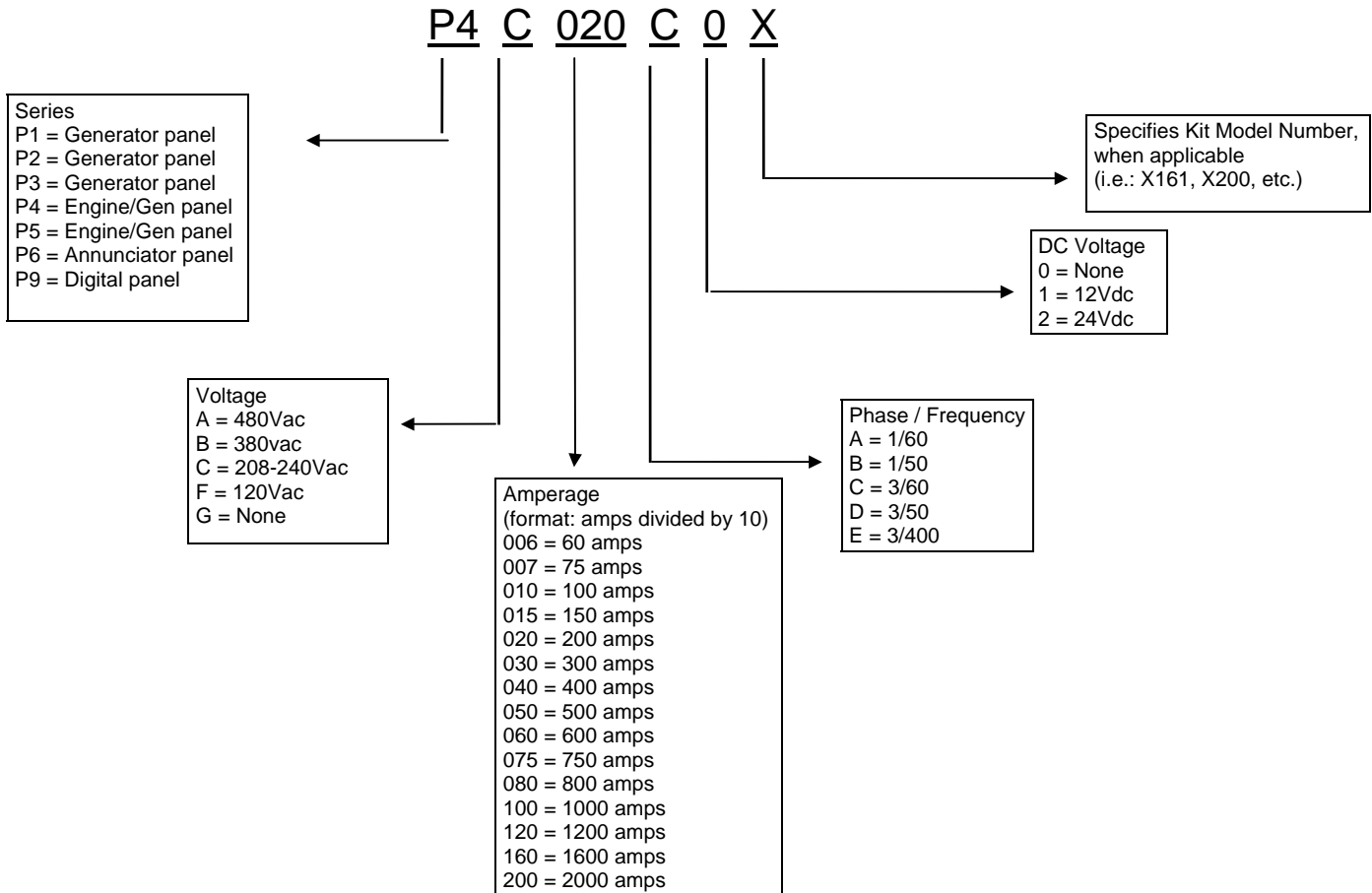

To order:

1. Determine the **Control Panel Series** required (P1, P2, P5, etc.)
2. Determine **System Parameters** (voltage, current, frequency, etc.).
3. Follow guide to obtain **Base Part Number**.
4. Review **Options List** to customize panel to your exact requirements.
5. Order online at www.panelsource.com or fax us your order at (386) 274-2279.

The part number, as derived from above, will be reflected on invoices and packing slips accompanying your control panel.

Warranty

Panelsource™ products are covered under a limited warranty against defective material and workmanship for a period of 12 months from date of shipment. This warranty is limited to the repair or replacement, at our factory, of product proved defective by our inspection. We do not assume responsibility for unauthorized repairs to our product, even if defective, and in no case shall it be understood that our responsibility extends to products other than those of our manufacture. Please see our Terms of Sale available on our website and also printed on Davidson Sales Company order acknowledgements and invoices for details of our Returns policy.

Panel Option Description Sheet

DS2	Up to 250Vac max, 3 phase wiring configuration.
DS3	Up to 480Vac max, 3 phase wiring configuration.
DS4	Dual scale (300/600) voltmeter. Meter input will be 300Vac max.
DS5	Voltage adjust rheostat for most voltage regulators. SPECIFY AVR.
DS6	Engine gauge package includes black bezel oil, water, battery volts and hourmeter with required senders ($\frac{1}{8}$ "NPT pressure sender & temperature sender kit).
DS7	VDO [®] gauge package. Includes black oil pressure and water temperature gauges & hourmeter. Complete with senders with warning contacts (217°F temperature setpoint and 7psi pressure setpoint).
DS10	Key start switch (Off-On-Start).
DS11	Panel lights. Two (2) DC powered lights with toggle switch and label.
DS13	Single element speed switch with warning light and label.
DS15	Auto Start engine controller upgrade with annunciator outputs.
DS16	Aux. fuel relay, 12Vdc, 40Adc. Required for auto start module operation.
DS17	Aux. fuel relay, 24Vdc, 20Adc. Required for auto start module operation.
DS18	Aux. start relay, 12Vdc, 70Adc. Required for auto start module operation.
DS19	Aux. start relay, 24Vdc, 70Adc. Required for auto start module operation.
DS20	Magnetic pickup per specific application.
DS21	Temperature safety switch per specific application. Required for engine shutdown.
DS22	Pressure safety switch per specific application. Required for engine shutdown.
DS24	Warning light 12Vdc or 24Vdc per specific application.
DS29	Energize to shutdown system. Temporarily energizes engine solenoid to shut-off engine. Includes timer and auxiliary relay.
DS31	Hourmeter installed and wired per specific application.
DS32	Extra switch (toggle or pushbutton) per specific application.
DS33	Remote speed potentiometer for most governor systems.
DS36	Cooldown timer. Allows for engine cooldown period during automatic operation. Available for auto start control panels only.
DS38	Auto Start engine controller upgrade with Preheat option. Includes auxiliary relay.
DS42	Engine gauge lights. Wiring of the DC internal gauge lights.
DS43	Manual start module with magnetic pickup sensing. The standard unit uses the generator's 60Hz output.
DS45	Engine harness 15' Length for P4X275 and P9X300.
DS46	Custom programming of select panel models.