

CTM Coolant Heating System

The Hotstart® CTM is a complete coolant preheater. It features an integrated pump that combines the benefits of forced circulation with a compact design that can mount to a variety of small engine applications. The CTM heats engines up to 20L displacement. Forced circulation of the coolant delivers uniform heating throughout the entire engine, extends element life and offers a significant reduction in electrical consumption.

Application:

The CTM was developed to preheat diesel and gas engines for stationary land power, marine and construction equipment.



Specifications:

- Heating Fluid: Engine coolant (50% glycol/50% water)
- Power: 1, 1.5 and 2.5 kW
- Rated Voltage: 1 Phase 120 and 240 Volt
- Tank Material: Glass fiber reinforced thermoplastic
- Adjustable T-Stat: 90° - 130°F (32° - 55°C)
Pre-set at 110°F (43.5°C)
- Ingress Protection: IP44
- Flow: 5GPM (1.14 m³/hr) @ 3 PSI (.21 bar)
- Inlet/Outlet: .625 inch (16mm) hose barb
- Cord or conduit connected

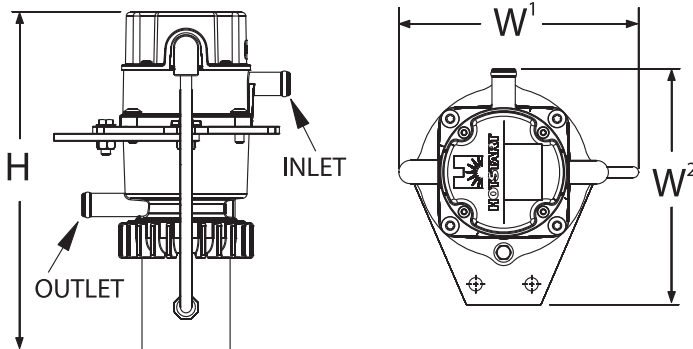

Pending UL listing. Not currently for use on UL listed generator sets.

Dimensions & Weight

Height	H	In (mm)	9.04	(230)
Width ¹	W	In (mm)	6.42	(163)
Width ²	W	In (mm)	6.32	(161)
Weight		lbs (kg)	2.9	(1.3)

Features:

- Pending UL evaluation
- CE compliant
- Compact design
- Easy to install
- Patent pending

Engine Size CID	Liter	Part Number 120V	Part Number 240V	Part Number 240V (Euro)	Kw	Amps 120V/240V
0 - 500	0-8	CTM101A3-N00	CTM102A3-N00	CTM102A3-E00	1	8.8/4.4
500 - 750	8-12	CTM151A3-N00	CTM152A3-N00	CTM152A3-E00	1.5	13.0/6.5
750 - 1200	12-20		CTM252A3-N00	CTM252A3-E00	2.5	21.3/10.7



www.kimhotstart.com

ISO 9001:2000