

HOTflow™ HEATING SYSTEM — CTM

HOTSTART's HOTflow™ heating system (CTM model) is a complete coolant preheater. It features an integrated pump that combines the benefits of forced circulation with a compact design that can mount to a variety of small engine applications. The CTM model heats engines up to 20L displacement. Forced circulation of the coolant delivers uniform heating throughout the entire engine, extends element life and offers a significant reduction in electrical consumption.



APPLICATION

HOTflow™ model CTM was developed to preheat diesel and gas engines for stationary land power, marine and construction equipment.

SPECIFICATIONS

- Heating Fluid: Engine coolant (50% glycol/50% water)
- Power: 1, 1.5 and 2.5 kW
- Rated Voltage: 1 Phase 120V, 60Hz, 240V 50/60Hz
- Tank Material: Glass fiber reinforced thermoplastic
- Adjustable T-Stat: 90° - 130°F (32°- 55°C)
Pre-set at 110°F (43.5°C)
- Ingress Protection**: IP44
- Flow*: 2.5GPM (.57 m³/hr) @ 1 PSI (.07 bar)
- Flow**: 2.5GPM (.57 m³/hr) @ 3 PSI (.21 bar)
- Inlet/Outlet: .625 inch (16mm) hose barb
- Cord connected with plug
- For use in weather protected applications

* - 120V models
** - 240V models

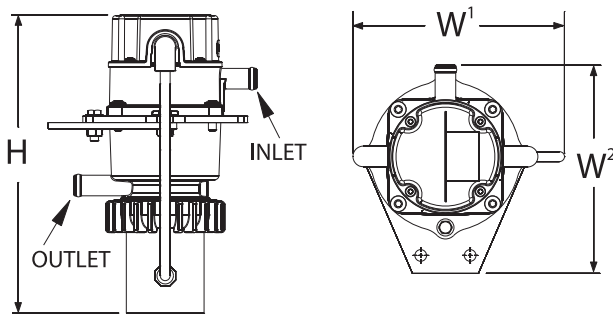

Dimensions & Weight

Phase	120V Models	240V Models
Height (H) In (mm)	10.0 (254)	9.04 (230)
Width1 (W) In (mm)	6.42 (163)	6.42 (163)
Width2 (W) In (mm)	6.32 (161)	6.32 (161)
Weight lbs (kg)	3.5 (1.6)	2.9 (1.3)

FEATURES

- UL C/US listed (E250789) models available
- CE compliant models available
- Compact design
- Easy to install
- Models with fixed thermostat available
- Patent # - D626570



HOTflow™ HEATING SYSTEM — CTM



PART NUMBERS

Engine Size CID	Engine Size Liter	Part Number 120V	Part Number 240V N. Am. power cord	Part Number 240V Euro power cord	kW	Amps 120V/240V
0-500	0-8	CTM101A3-A01	CTM102A3-N00 CTM102A3-A00	CTM102A3-E00	1	8.8/4.4
500-750	8-12	CTM151A3-A01	CTM152A3-N00 CTM152A3-A00	CTM152A3-E00	1.5	13.0/6.5
750-1200	12-20	CTM251A3-A01	CTM252A3-N00 CTM252A3-A00	CTM252A3-E00	2.5	21.3/10.7

UL C/US listed Models

Engine Size CID	Engine Size Liter	Part Number 120V	kW	Amps 120V
0-500	0-8	CTM101A3-N01	1	8.8
500-750	8-12	CTM151A3-N01	1.5	13.0
750-1200	12-20	CTM251A3-N01	2.5	21.3

Suffix Descriptions

Suffix	Description	Industry Approvals
A00	3m cord, no plug Laing pump	
A01	3m cord, no plug Grundfos pump	
E00	Schuko plug Laing pump	CE compliant
N00	NEMA plug Laing pump	
N01	NEMA plug Grundfos pump	UL C/US listed

