

GENERATOR SET ANNUNCIATOR



- 20 Light annunciator meets or exceeds requirements of NFPA 110, NFPA 99 & CSA 282-00 building code standards for Emergency Standby Generator systems
- RS 422 Data Communication capability saves installation time & reduces costs
- Programmable annunciation & labeling allows excellent flexibility for different applications
- Automatic “ringback” & flashing annunciator lights provides excellent status indication of existing & incoming fault conditions
- 4 fault annunciation circuits can be activated from external hardwired contacts for added system capability
- Multiple EAP 110 Annunciators can be easily interconnected to provide up to 40 remote annunciation lights from a single MEC 20 engine controller

DESCRIPTION

The **EAP 110** annunciator is designed for remote fault annunciation of emergency standby generator sets utilizing **Thomson Technology MEC 2 & MEC 20** Engine Controllers. The advanced design uses a RS 422 communication data link to provide the control & monitoring signals between the engine controller and remote annunciator. The communication link allows a simple, cost effective system installation at any building site. Up to 20 individual fault conditions are remotely monitored utilizing both visual LED lights & audible alarm annunciation. Lamp test and alarm horn silence pushbuttons are provided. Each fault is individually programmable for audible horn operation and alarm labels are field configurable. Operation logic includes a

“auto-ringback” feature to annunciate subsequent alarm conditions. For applications requiring additional alarm annunciation from remote sensing contacts, the **EAP 110** can accept up to 4 hardwired contact inputs dependant upon the alarm configuration. The **EAP 110** is DC powered typically from a 12 or 24V engine starting battery. Two **EAP 110** annunciators can be interconnected together via the communication link to allow up to 40 remote annunciator points from a single MEC 20 engine controller (consult Thomson Technology for further details). The standard features of the **EAP 110** meet and exceed all requirements of NFPA 110, NFPA 99 & CSA 282-00 building code standards for Emergency Standby Generator systems.



SPECIFICATIONS

SUPPLY VOLTAGE	12V or 24V nominal ($\pm 20\%$), negative ground
SUPPLY CURRENT	100 ma (maximum), ($\pm 20\%$)
COMMUNICATION PORT	RS 422, 4.8 Kbaud, Thomson Technology T-Net Protocol to MEC2/MEC20 8 conductor #22 AWG (min.) Shielded/Twisted cable (1000 ft Max.), Plug-in RJ45 Connector
DIGITAL CONTACT INPUT	Close to DC Negative
TEMPERATURE RANGE	-40° C TO + 50° C
ENVIRONMENTAL	Faceplate NEMA 12, Rear Enclosure NEMA 1
DIMENSIONS	6.0" W x 6.0" H x 3.0" D (7.0" W x 7.0" H)
Flush mount adapter option	
MOUNTING	Surface Mount (Standard), Flush-mount (Optional) Rear Enclosure conduit box c/w Qty. 8 1/2" knockouts

ORDERING INFORMATION

The EAP 110 may be ordered separately or in conjunction with the unit mount control panels or engine controllers. When ordering for use with existing MEC 2/MEC 20 engine controller applications in the field, contact Thomson Technology for additional information regarding software/hardware compatibility.

The EAP 110 is supplied from the factory with standard alarm labeling for MEC 2* or MEC 20* engine controllers which are applied to meet NFPA 110 Level 1/NFPA 99 or CSA 282 alarm requirements. The standard EAP 110 can be labeled and programmed for alternate alarm configurations (consult Thomson Technology for further information). When specified, the optional flush mount adapter plate is supplied loose with the standard Annunciator for field installation.

EXAMPLE:

EAP 110 - S

BASIC MODEL _____

MOUNTING _____

S = SURFACE (Standard)
F = FLUSH (Optional)

*Note: For MEC 2 / MEC 20 details refer to separate brochures.

EXTERNAL CONNECTIONS

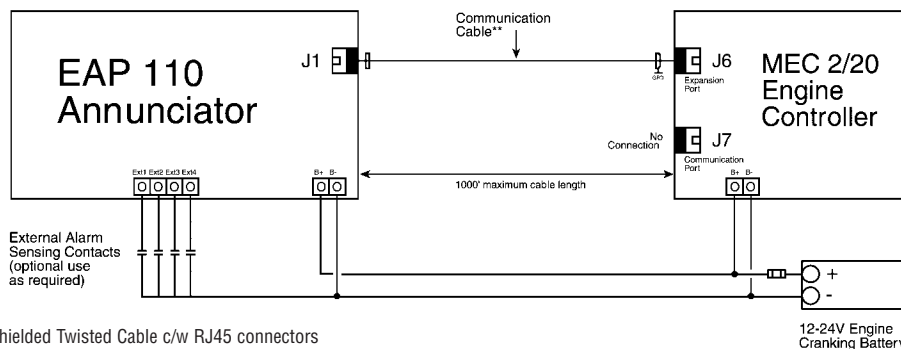

** 8 conductor Shielded Twisted Cable c/w RJ45 connectors

NOTE: Specifications subject to change without notice.

CL057 Rev 1 04/06/01