

# AUTOMATIC ENGINE CONTROL FOR DIESEL/GAS ENGINES

The **ECU-9988L** engine control provides complete automation and safety monitoring of a gas or diesel engine. The **ECU-9988L** controls the starter and fuel thus completely taking the operator out of the picture. A built in speed switch controls both starter disengagement and overspeed protection.

**ECU-9988L**

ONE VERSION FOR  
12 OR 24 VDC

**APPLICATIONS:** Generator Control Panels, Automatic Engine Systems

## FEATURES:

- NEW** \* Loss of Magnetic Pickup detection during both cranking and running
- \* Single or Multi-crank modes are field adjustable
- \* Built in speed switch
- \* Grounded or positive HWT/LOP inputs
- NEW** \* Low oil pressure and high water temp override during cranking
- \* Wide temperature range -40C to +85C
- \* Epoxy encapsulated module for excellent field reliability
- NEW** \* LEDs with auto/manual lamp test

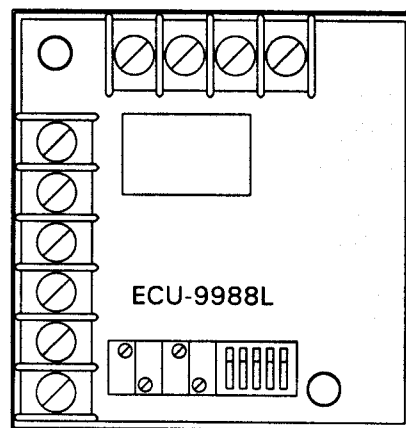

BACK VIEW

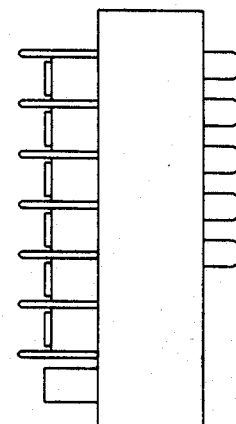

SIDE VIEW

## ECU-9988L A COMPLETE AUTOMATIC ENGINE CONTROL

The ECU-9988L covers just about all the essential engine control functions that are asked for in most specifications.

The ECU-9988L automatically cranks, starts and monitors an engine for Overcrank, Overspeed, High Water Temperature and Low Oil Pressure. Any crank timing sequence is accomplished by using the multiple or single crank modes in conjunction with the timer adjustments. A built in speed switch uses a magnetic pickup to monitor engine speed for crank disconnect and overspeed. The bypass timer/logic assures Low Oil Pressure and High Water Temp override during the crank period and an additional adjustable period after crank disconnect.

The ECU-9988L expands to as many faults as required by using the Engine Alarm Input.

The ECU-9988L monitors the Magnetic Pickup signal for problems during both cranking and running. If a problem is detected the engine will shutdown and the Overcrank and Overspeed LED's will both turn on.

**ECU**<sup>®</sup> IS A REGISTERED TRADEMARK OF  
**ENGINEERING CONCEPTS UNLIMITED, INC.**

P.O. Box 250 - 8950 Technology Drive - Fishers, IN 46038

# SAMPLE ECU-9988L APPLICATION: AUTOMATIC ENGINE CONTROL OF DIESEL/GAS ENGINE

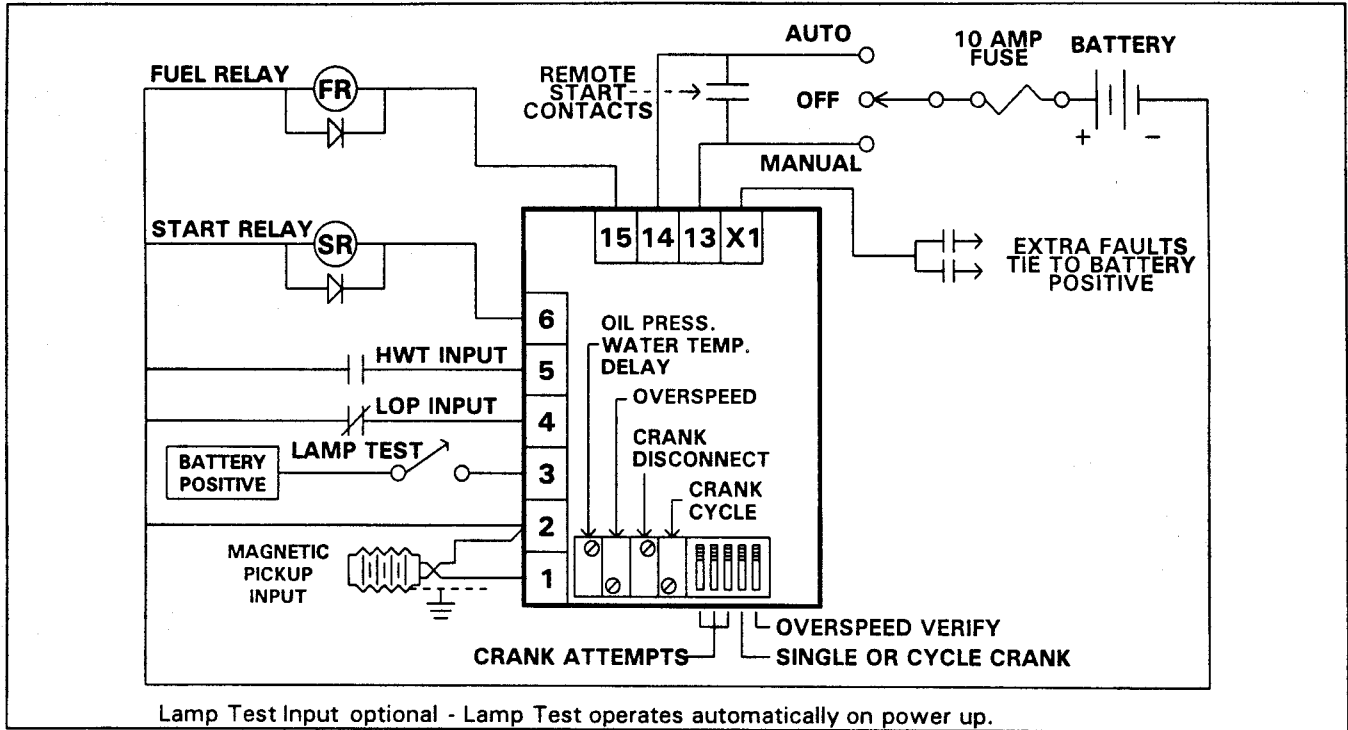

The above illustrates the ECU-9988L engine control with an energized to run engine. Placing the control switch in MANUAL or closure of the Remote Start Contacts while in AUTO initiates the Crank mode. The Fuel and Starter Relays are energized causing the engine to begin cranking. If the engine does not start in the allotted time, as determined by the Crank Cycle Adjust and Dip Switch setting, the Overcrank Fault occurs, and the Fuel and Starter Relays are turned off. If during cranking the internal speed switch detects a speed equal to or above the Crank Disconnect Adjustment Setting the Starter Relay turns off, the LOP/HWT delay timer is initiated. After this delay period if the LOP or HWT switch closes the engine will shutdown immediately. If the internal speed switch detects a speed equal to or above the Overspeed Adjustment Setting the engine is shutdown immediately. To stop the engine or to clear a fault condition place the control switch if the Off position. If the signal from the magnetic pickup is lost during cranking or running the engine will shut down and the Overcrank & Overspeed LED's will both turn on.

**SPECIFICATIONS:**  
 VOLTAGE RANGE - 9 TO 28 VOLTS  
 MAGNETIC PICKUP - 250 TO 8500 HERTZ  
 STARTER AND FUEL OUTPUTS - 5 AMPS MAX

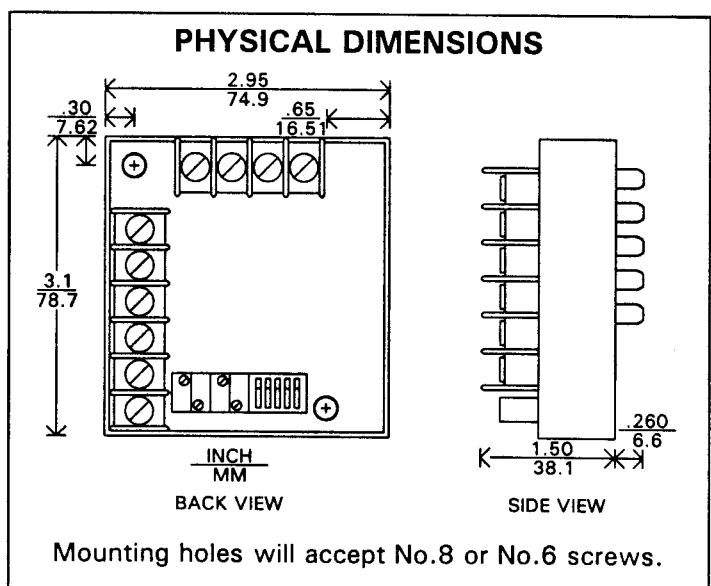
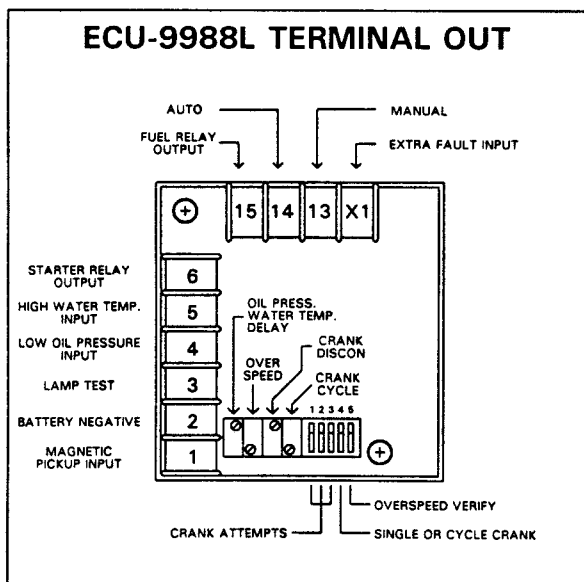

**ORDERING INFORMATION:**  
 ORDER BY SPECIFYING: ECU-9988L

**ECU<sup>®</sup>** IS A REGISTERED TRADEMARK OF  
**ENGINEERING CONCEPTS UNLIMITED, INC.**