



## DESCRIPTION

The 703 is an engine auto start and protection module. It utilizes advanced surface mount construction techniques to provide a compact, yet highly specified module.

Operation is via three pushbuttons mounted on the front panel with STOP, MANUAL and AUTO positions.

## OPERATION

**Stop mode** - This is used to stop the engine when it is running and to cancel 'Auto' mode. It is also used to reset any Shutdown Alarm conditions.

**Manual mode** - This mode is used to manually start and run the engine, which can be stopped by pressing the Stop button.

**Auto mode** - This selects the automatic mode of operation, in which the module will await the remote start signal. Once received, the module will initiate its pre-configured Start Sequence, observing the start delay timer before starting the engine. When the remote start signal is removed, the module will initiate its pre-configured Stopping Sequence.

The module monitors the engine and provides the following functions:

- Automatic Start with 3 attempts and Automatic Crank Disconnect - with adjustable Start and Stop Timers and Fail to Start indication.
- Configurable Pre-heat and Energize to Stop functions.
- Low Oil Pressure and High Engine Temperature Shutdown.
- Overspeed and Underspeed (frequency) protection.
- Charge Fail Alarm
- Two fully configurable auxiliary inputs.

All alarms are indicated by high visibility red LED's.

The module's microprocessor provides a comprehensive list of timers and configurable functions. Parameter settings can be adjusted using the front panel pushbuttons once in Configuration Mode. Access to the settings is via a small 'Configuration Switch' on the rear of the module (see figs. 1 and 2), and enables changes to be made in the field.

Selection of the Configuration Mode is indicated by rapid flashing of the 'Auto' LED.

The module is designed with DSE's proven experience and uses modern construction to provide a high level of reliability and suitability for the intended operating environment. Issues such as environmental compliance and EMC have been carefully engineered into the design. Advanced features such as protected solid state outputs mean that there are no moving parts or contacts to burn-out.

## FEATURES

- Micro-processor based design
- Automatic Engine Starting and Stopping
- Automatic Shutdown on fault condition
- Configurable via front panel
- Simple pushbutton controlled operation
- Configurable Digital Inputs
- Configurable Solid State Outputs
- Configurable Timer Settings
- Solid State Fuel and Crank outputs
- External Remote Start input
- LED Alarm indication
- Start Delay Timer
- Stop Delay Timer
- Energize to Stop timer
- Pre-heat Timer
- Over Speed Shutdown
- Optional Underspeed Protection
- Low Oil Pressure Shutdown
- High Engine Temp Shutdown
- Optional Crank Disconnect from Oil Pressure

*The 700 series modules have been designed for front panel mounting. The module is fitted into the cut-out, and screw holes are provided for secure fixing.*



## SPECIFICATION

- **DC Supply:**  
8 to 35 V Continuous.
- **Cranking Dropouts:**  
Able to survive 0 V for 50 ms, providing supply was at least 10 V before dropout and supply recovers to 5V. This is achieved without the need for internal batteries.
- **Max. Current:**  
Operating 50mA  
Standby 10mA
- **Alternator Input Range:**  
75(ph-N) to 277(ph-N) 3 Phase  
4wire AC (+20%)
- **Alternator Input Frequency:**  
50 - 60 Hz at rated engine speed  
(Minimum: 75V AC Ph-N) (Crank Disconnect from 15V Ph-N @ 20 Hz)  
Overspeed +14% (+24% overshoot)  
Underspeed -20%
- **Start Output:**  
1.2 Amp DC at supply voltage.
- **Fuel Output:**  
1.2 Amp DC at supply voltage.
- **Auxiliary Outputs:**  
1.2 Amp DC at supply voltage.
- **Dimensions:**  
125 X 165 X 28 mm
- **Charge Fail:**  
12V = 8V CF 24V = 16V CF
- **Operating Temperature Range:**  
-30 to +70° C
- **Compliant with BS EN 60950 Low Voltage Directive**
- **Compliant with BS EN 50081-2 EMC Directive**
- **Compliant with BS EN 50082-2 EMC Directive**

# CONFIGURATION

Configuration Mode is selected by operation of a small switch on the rear, left-hand edge of the PCB. This is partially hidden to prevent accidental operation. See *figs 1 and 2*

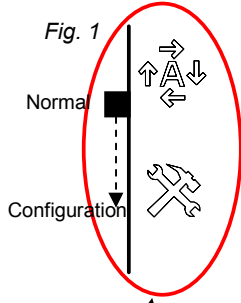

Once Configuration Mode is selected, the 'Auto' LED will commence rapid flashing. When in Configuration Mode all normal operation is suspended. The 'Stop' pushbutton can be used to select the LED 'code' that corresponds to the required function. The 5 left hand LED's will form the code. The 'Manual' pushbutton will allow the user to change the function parameters. The 3 right-hand LED's inform the user of the current value for the chosen function. When the required parameters are displayed, pressing the 'Auto' button will save the new setting. The process is repeated for each function change. When configuration is complete, the Configuration Mode Selector Switch should be returned to the 'Normal' position. A key to all configuration options is provided (refer to Installation Instructions supplied with module).

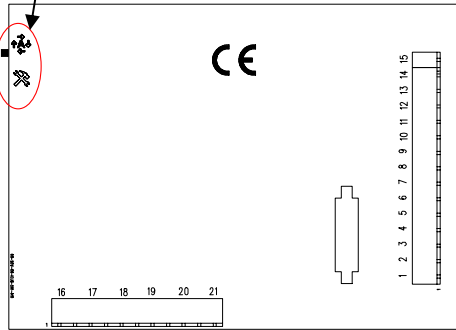

Fig. 2  
Diagram of reverse side of 703

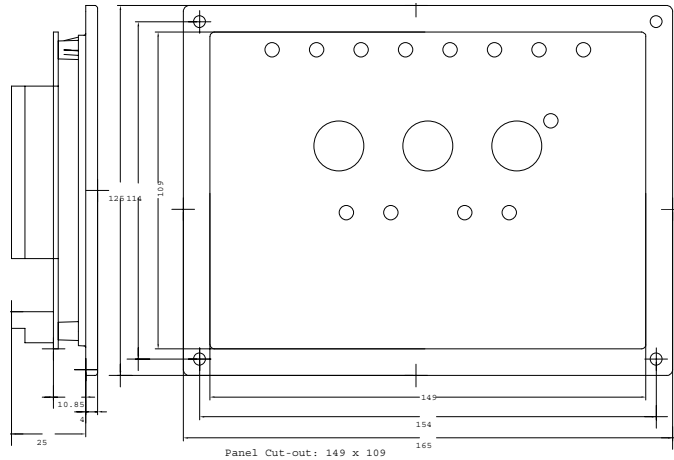
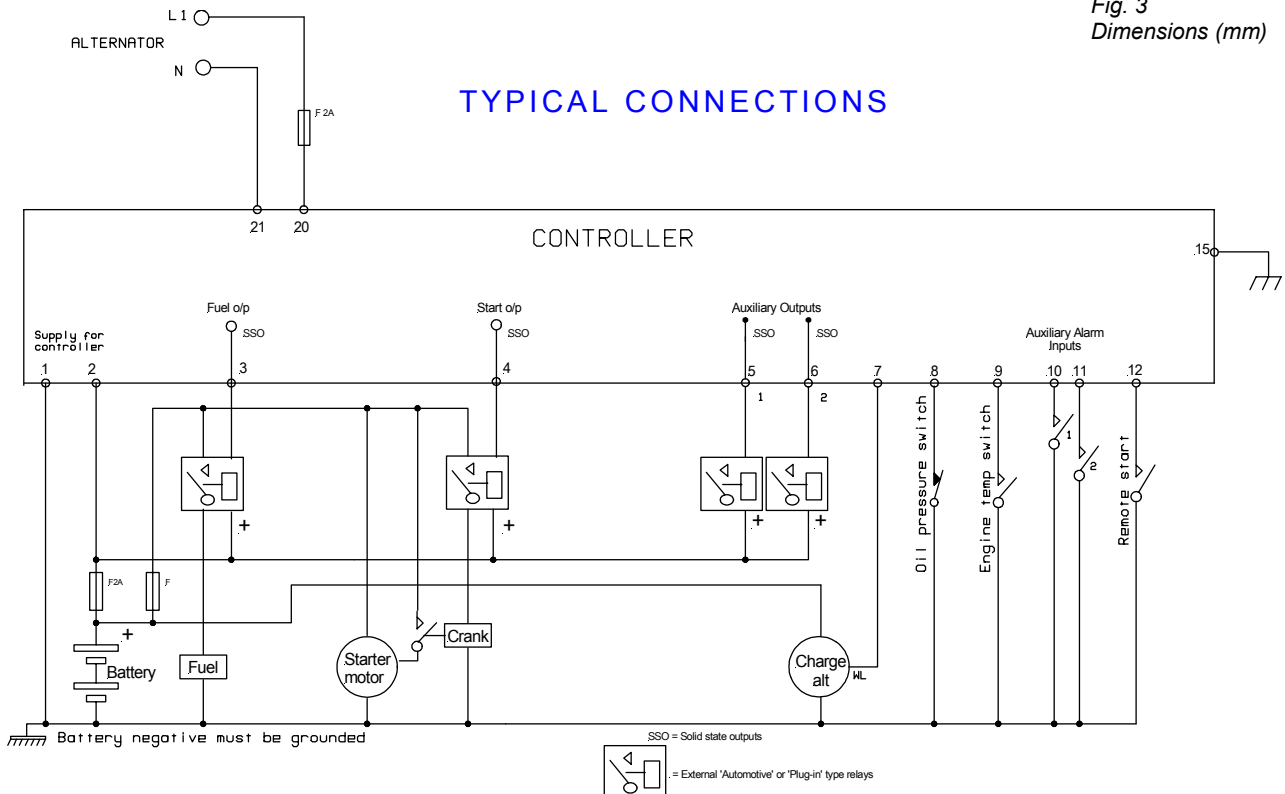

Fig. 3  
Dimensions (mm)

# TYPICAL CONNECTIONS



Deep Sea Electronics plc

Highfield House, Hunmanby Industrial Estate, North Yorkshire, YO14 0PH, England  
Tel: +44 (0) 1723 890099 Fax: +44 (0) 1723 893303 E-mail sales@deepseapl.com