



DEEP SEA ELECTRONICS PLC

**703 AUTOMATIC START MODULE
OPERATING INSTRUCTIONS**

Author:- John Ruddock

<< This page is intentionally blank >>

TABLE OF CONTENTS

1 DESCRIPTION OF OPERATION	4
1.1MANUAL MODE OPERATION	4
1.2AUTOMATIC MODE OF OPERATION	5
1.3WARNINGS	6
1.4SHUTDOWNS.....	6
2 CONFIGURATION INSTRUCTIONS	7
3 CONFIGURATION TABLES	8
4 TERMINAL DESCRIPTION	11
5 SPECIFICATION	12
6 SOLID STATE OUTPUTS	13
6.1TYPICAL CONNECTIONS	13
7 ADDING A LOAD TRANSFER OUTPUT	14
7.1CONNECTION DETAILS.....	14
7.2DESCRIPTION.....	14
7.3CONFIGURATION DETAILS	14
8 DIMENSIONS	15
9 TYPICAL CONNECTIONS	15

1 DESCRIPTION OF OPERATION

1.1 MANUAL MODE OPERATION

To initiate a start sequence in **MANUAL**, press the  pushbutton, and the start sequence is initiated.

 **NOTE:- There is no Start Delay in this mode of operation.**

If the **pre-heat** output option is selected this timer is then initiated, and the auxiliary output selected is energised.

After the above delay the **Fuel Solenoid** is energised, then the **Starter Motor** is engaged.

The engine is cranked for a 10-second period. If the engine fails to fire during this cranking attempt then the starter motor is disengaged for a 10-second period. Should this sequence continue beyond the 3 starting attempts, the start sequence will be terminated and **Fail to Start**  fault will be illuminated.

When the engine fires, the starter motor is disengaged and locked out at 20 Hz measured from the Alternator output. Rising oil pressure can also be used to disconnect the starter motor, however it cannot be used for underspeed or overspeed detection.

After the starter motor has disengaged, the **Safety On** timer is activated (which is fixed at 12 seconds), allowing Oil Pressure, High Engine Temperature, Under-speed, Charge Fail and any delayed Auxiliary fault inputs to stabilise without triggering the fault.

Selecting **STOP**  de-energises the **FUEL SOLENOID**, bringing the generator to a stop.

 **NOTE:- The safety on time (used for delayed alarms) is pre set to 12 seconds and can not be changed.**

1.2 AUTOMATIC MODE OF OPERATION

This mode is activated by pressing the **Auto**  pushbutton. An LED indicator beside the button confirms this action.

The start sequence is initiated when the remote start input is activated. To allow for false remote start signals, the Start Delay timer is initiated. After this delay, if the pre-heat output option is selected then the pre-heat timer is initiated, and the corresponding auxiliary output (if configured) will energise.

 **NOTE: - If the Remote Start signal is removed during the Start Delay timer, the unit will return to a stand-by state.**

After the above delays the **Fuel Solenoid** is energised, then one second later, the **Starter Motor** is engaged.

The engine is cranked for a 10-second period. If the engine fails to fire during this cranking attempt then the starter motor is disengaged for a 10-second rest period. Should this sequence continue beyond the 3 starting attempts, the start sequence will be terminated and

Fail to Start  fault will be illuminated.

When the engine fires, the starter motor is disengaged and locked out at 20 Hz measured from the Alternator output. Rising oil pressure can also be used to disconnect the starter motor, however it cannot be used for underspeed or overspeed detection.

After the starter motor has disengaged, the **Safety On** timer is activated, allowing Oil Pressure, High Engine Temperature, Under-speed, Charge Fail and any delayed Auxiliary fault inputs to stabilise without triggering the fault.

Once the engine is running, the output **Generator Running** is activated if it has been configured.

On removal of the **Remote Start** signal the **Stop** delay timer is initiated. Once this timer has expired the **Fuel Solenoid** is de-energised, bringing the generator to a stop.

 **NOTE: - The safety on time (used for delayed alarms) is pre set to 12 seconds and can not be changed.**

1.3 WARNINGS

Warnings are used to warn the operator of an impending fault

BATTERY CHARGE FAILURE, if the module does not detect a voltage from the warning light terminal on the auxiliary charge alternator, the  icon will illuminate. (Either 8 Volts or 16 Volts, depending on the configuration of **Nominal DC Voltage**).

Inputs 1 and 2 can be configured as warnings or shutdowns. The relevant icon will be illuminated when the input is active

1.4 SHUTDOWNS

Shutdowns are latching and stop the Generator. The alarm must be cleared, and the fault removed to reset the module. In the event of a shutdown the appropriate icon will be illuminated

 **NOTE:** - The alarm condition must be rectified before a reset will take place. If the alarm condition remains it will not be possible to reset the unit (The exception to this is the Low Oil Pressure alarm and similar 'delayed alarms', as the oil pressure will be low with the engine at rest). Any subsequent warnings or shutdowns that occur will be displayed steady, therefore only the first-up shutdown will appear flashing.

 **NOTE:** - The safety on time (used for delayed alarms) is pre set to 12 seconds and can not be changed.

FAIL TO START, if the engine does not fire after the pre-set 3 attempts at starting, a shutdown will be initiated.

The  icon will illuminate.

LOW OIL PRESSURE, if the module detects that the engine oil pressure has fallen below the low oil pressure switch after the **Safety On** timer has expired, a shutdown will occur.

The  icon will illuminate.

HIGH ENGINE TEMPERATURE if the module detects that the engine coolant temperature has exceeded the high engine temperature switch after the **Safety On** timer has expired, a shutdown will occur.

The  icon will illuminate.

OVERSPEED, if the engine speed exceeds the pre-set trip (14% above the nominal frequency) a shutdown is initiated. Overspeed is not delayed, it is an **immediate shutdown**.

The  icon will illuminate.

 **NOTE:-** During the start-up sequence the overspeed trip level is extended to 24% above the normal frequency for the duration of the safety timer to allow an extra trip level margin. This is used to prevent nuisance tripping on start-up.

UNDERSPEED, if the engine speed falls below the pre-set trip (20% of the nominal frequency) after the **Safety On** timer has expired, a shutdown is initiated.



The  icon will illuminate.

Inputs 1 and 2 can be configured as warnings or shutdowns. The relevant icon will be illuminated when the input is active

2 CONFIGURATION INSTRUCTIONS

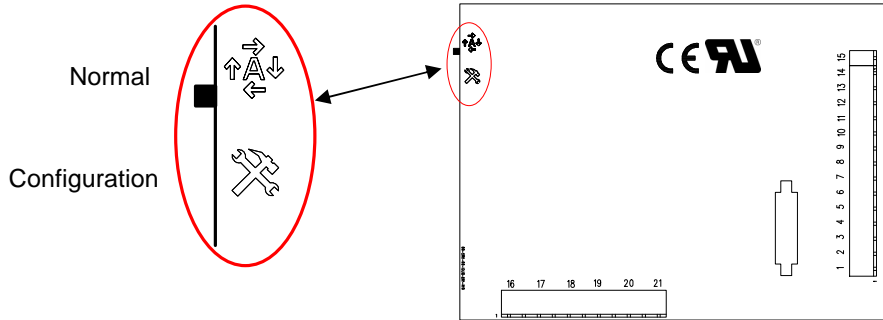
- ? With the unit in **Stop**  mode, **Configuration Mode** is selected by operation of a small switch on the rear, left-hand edge of the PCB. This is partially hidden to prevent accidental operation.



- ? Once **Configuration Mode** is selected, the 'Auto' LED will commence rapid flashing, and all normal operation is suspended.
- ? The **Stop**  pushbutton can be used to select the LED 'code' that corresponds to the required function. The 5 left-hand LED's will form the code. See configuration table over leaf.
- ? The **Manual**  pushbutton will allow the user to change the associated value. The 3 right-hand LED's inform the user of the current setting for the chosen function. See configuration table over leaf.
- ? When the required parameters are displayed, pressing the **Auto**  button will save the new setting, and the process is repeated for each function change.
- ? When configuration is complete, the **Configuration Mode** Selector Switch should be returned to the 'Normal' position.

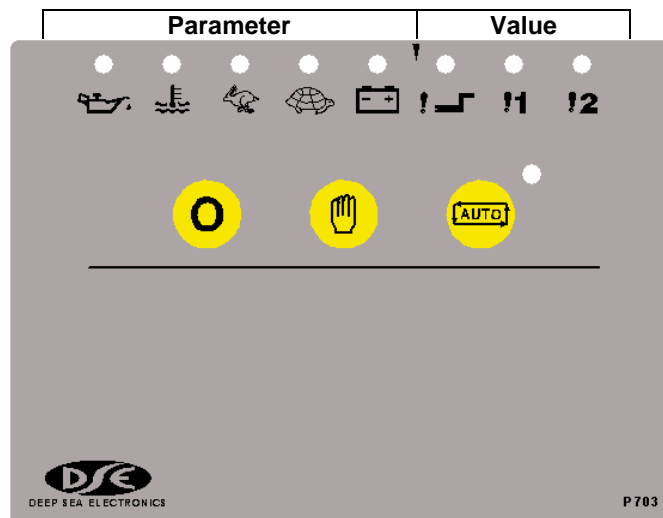

3 CONFIGURATION TABLES

FUNCTIONS AND CONFIGURATION TABLE									
Function							! 1	! 2	Value (Default in Bold)
Pre-heat Timer							↘	↘	0 Seconds
							↘	†	5 Seconds
							↘	†	10 Seconds
							↘	†	15 Seconds
							†	↘	20 Seconds
							†	↘	30 Seconds
							†	†	60 Seconds
							†	†	180 Seconds
Used to pre-heat the engine prior to cranking. The output is active for the duration of the setting, prior to cranking.									
Start Delay							↘	↘	0 Seconds
							↘	†	5 Seconds
							↘	†	10 Seconds
							↘	†	15 Seconds
							†	↘	20 Seconds
							†	↘	30 Seconds
							†	†	60 Seconds
							†	†	180 Seconds
Used to give a delay between activating the remote start input and actually starting the engine.									
Stop Delay							↘	↘	0 Seconds
							↘	†	5 Seconds
							↘	†	10 Seconds
							↘	†	15 Seconds
							†	↘	20 Seconds
							†	↘	30 Seconds
							†	†	60 Seconds
							†	†	180 Seconds
Used to give a delay between deactivating the remote start input and actually stopping the engine.									
Energise to Stop Hold Timer							↘	↘	0 Seconds
							↘	†	5 Seconds
							↘	†	10 Seconds
							↘	†	15 Seconds
							†	↘	20 Seconds
							†	↘	30 Seconds
							†	†	60 Seconds
							†	†	180 Seconds
Used for the control of the engine stop solenoid. When the engine is to be stopped, the Energise To Stop output becomes active, closing the stop solenoid (fuel valve). When the engine comes to rest, the stop solenoid will remain energised for the period of the Energise To Stop Timer, to ensure the engine has come to a complete stop.									
Nominal Frequency			†				↘	↘	50 Hz (O/S +14% / Overshoot +24%)
							↘	†	60 Hz (O/S +14% / Overshoot +24%)
The systems nominal frequency. Either 50 Hz or 60 Hz									
Nominal DC Voltage			†				↘	↘	12V DC (CF 8V)
							↘	†	24V DC (CF 16V)
The generator battery voltage. Either 12 Volts or 24 Volts. It is used for the charge alternator failure level.									
LOP Switch Contact			†				↘	↘	Close on Fault
							↘	†	Open on Fault
Configuration for the oil pressure switch. Either to close to battery negative on a fault, or open on a fault.									

FUNCTIONS AND CONFIGURATION TABLE									
Function							! 1	! 2	Value (Default in Bold)
HET Switch Contact	↘	↑	↘	↑	↑	↘	↘	↘	Close on Fault
								↑	Open on Fault
Configuration for the coolant temperature switch. Either to close to battery negative on a fault, or open on a fault.									

Crank disconnect on Oil Pressure	↘	↑	↑	↘	↘	↘	↘	↘	Disabled
								↑	Enabled (2 Second Delay)
If this is enabled, the starter motor will disconnect 2 seconds after the oil pressure switch detects oil pressure.									
NOTE:- Not suitable for all generators, due to the different monitoring points on lubrication systems.									

Underspeed Detection	↘	↑	↑	↘	↑	↘	↘	↘	Disabled
								↑	Enabled (U/S -20%)
If this is enabled, the unit will shut down the generator if the frequency falls below 20% of the nominal frequency.									

Auxiliary Input 1 Function	↑	↘	↘	↘	↘	↘	↘	↘	Immediate Warning Close on Fault
								↑	Immediate Warning Open on Fault
							↑	↘	Immediate Shutdown Close on Fault
							↑	↑	Immediate Shutdown Open on Fault
	↑	↘	↘	↘	↘	↘	↘	↘	Delayed Warning Close on Fault
	↑	↘	↘	↘	↘	↘	↘	↑	Delayed Warning Open on Fault
	↑	↑	↘	↘	↘	↘	↘	↘	Delayed Shutdown Close on Fault
	↑	↑	↑	↑	↑	↑	↑	↑	Delayed Shutdown Open on Fault

Programmable input, can be configured to on of the following

- ? Immediate warning close on fault – If the input is activated at any time the unit will alarm and energise the common warning and common alarm output.
- ? Immediate warning open on fault – If the input is deactivated at any time the unit will alarm and energise the common warning and common alarm output.
- ? Immediate shutdown close on fault – If the input is activated at any time the generator will be shutdown and energise the common warning and common shutdown output. The generator can not be started.
- ? Immediate shutdown open on fault – If the input is deactivated at any time the generator will be shutdown and energise the common warning and common shutdown output. The generator can not be started.
- ? Delayed warning close on fault – If the input is activated and the safety time has elapsed the unit will alarm and energise the common warning and common alarm output.
- ? Delayed warning open on fault – If the input is deactivated and the safety time has elapsed the unit will alarm and energise the common warning and common alarm output.
- ? Delayed shutdown close on fault – If the input is activated and the safety time has elapsed the generator will be shutdown and energise the common warning and common shutdown output.
- ? Delayed shutdown open on fault – If the input is deactivated and the safety time has elapsed the generator will be shutdown and energise the common warning and common shutdown output.

FUNCTIONS AND CONFIGURATION TABLE									
Function							! 1	! 2	Value (Default in Bold)
Auxiliary Input 2 Function	†	↯	↯	↯	↯	†	↯	↯	Immediate Warning Close on Fault
							↯	†	Immediate Warning Open on Fault
							†	↯	Immediate Shutdown Close on Fault
							†	†	Immediate Shutdown Open on Fault
							†	↯	Delayed Warning Close on Fault
							†	†	Delayed Warning Open on Fault
							†	↯	Delayed Shutdown Close on Fault
							†	†	Delayed Shutdown Open on Fault
Programmable input, can be configured to on of the following <ul style="list-style-type: none"> ? Immediate warning close on fault – If the input is activated at any time the unit will alarm and energise the common warning and common alarm output. ? Immediate warning open on fault – If the input is deactivated at any time the unit will alarm and energise the common warning and common alarm output. ? Immediate shutdown close on fault – If the input is activated at any time the generator will be shutdown and energise the common warning and common shutdown output. The generator can not be started. ? Immediate shutdown open on fault – If the input is deactivated at any time the generator will be shutdown and energise the common warning and common shutdown output. The generator can not be started. ? Delayed warning close on fault – If the input is activated and the saftey time has elapsed the unit will alarm and energise the common warning and common alarm output. ? Delayed warning open on fault – If the input is deactivated and the saftey time has elapsed the unit will alarm and energise the common warning and common alarm output. ? Delayed shutdown close on fault – If the input is activated and the saftey time has elapsed the generator will be shutdown and energise the common warning and common shutdown output. ? Delayed shutdown open on fault – If the input is deactivated and the saftey time has elapsed the generator will be shutdown and energise the common warning and common shutdown output. 									

Auxiliary Output 1 Function	†	↯	↯	†	↯	↯	↯	↯	Not used
							↯	†	Pre-heat
							†	↯	Engine Running
							†	†	Common Warning
							†	↯	Common Shutdown
							†	†	System in Auto
							†	†	Common Alarm
							†	†	Energise to Stop
Programmable output can be configured to one of the following. <ul style="list-style-type: none"> ? Pre-heat. - The output is energised for the period of pre-heat time prior to cranking, and between the cranking attempts. ? Engine Running. - The output is active after the saftey timer has elapsed. ? Common warning. - The output is active if there are any warning alarm active. ? Common shutdown - The output is active if there are any shutdown alarms active. ? System in auto. - The output is active when the system is in automatic mode. ? Common Alarm. - The output is active if there is any alarm condition. ? Energise to stop. - The output is energised when the engine is required to stop (normal or fault conditions), and will remain energised for the period of the Energise To Stop Timer, to ensure the engine has come to a complete stop. 									

FUNCTIONS AND CONFIGURATION TABLE									
Function							! 1	! 2	Value (Default in Bold)
Auxiliary Output 2 Function	†	≤	≤	†	†	≤	≤	≤	Not used
						≤	≤	†	Pre-heat
						≤	†	≤	Engine Running
						≤	†	†	Common Warning
						†	≤	≤	Common Shutdown
						†	≤	†	System in Auto
						†	†	≤	Common Alarm
						†	†	†	Energise to Stop
Programmable output can be configured to one of the following. ? Pre-heat. - The output is energised for the period of pre-heat time prior to cranking, and between the cranking attempts. ? Engine Running. - The output is active after the safety timer has elapsed. ? Common warning. - The output is active if there are any warning alarm active. ? Common shutdown - The output is active if there are any shutdown alarms active. ? System in auto. - The output is active when the system is in automatic mode. ? Common Alarm. - The output is active if there is any alarm condition. ? Energise to stop. - The output is energised when the engine is required to stop (normal or fault conditions), and will remain energised for the period of the Energise To Stop Timer, to ensure the engine has come to a complete stop.									

4 TERMINAL DESCRIPTION

PIN No	DESCRIPTION	CABLE SIZE	NOTES
1	DC Plant Supply Input (-ve)	1.0mm	Connected to plant battery negative
2	DC Plant Supply Input (+ve)	1.0mm	Connected to plant battery positive (Recommended Fuse 2A)
3	Fuel relay Output	1.0mm	Used to operate the fuel relay.
4	Start relay Output	1.0mm	Used to operate the cranking relay.
5	Auxiliary Output relay 1	1.0mm	Configurable output.
6	Auxiliary Output relay 2	1.0mm	Configurable output.
7	Charge Fail Input/ Excitation Output	1.0mm	Must NOT be connected to plant supply negative if not used.
8	Low Oil Pressure Input	0.5mm	Switch to negative.
9	High Engine Temp Input	0.5mm	Switch to negative.
10	Auxiliary Input 1	0.5mm	Switch to negative.
11	Auxiliary Input 2	0.5mm	Switch to negative.
12	Remote Start Input	0.5mm	Switch to negative.
13	Not Used		
14	Not Used		
15	Functional Earth	1.0mm	Connect to a good clean earth point
16	Not Used		
17	Not Used		
18	Not Used		
19	Not Used		
20	Alternator Input L1	1.0mm	Do not connect if not used. (2A Fuse)
21	Alternator Input N	1.0mm	Do not connect if not used.

NOTE:- All the outputs are solid state, rated at 1.2 Amps 8 Volts to 35 Volts DC, and switch to battery negative when active.

5 SPECIFICATION

DC Supply:	8 Volts to 35 Volts DC Continuous.
Cranking Dropouts:	Able to survive 0 Volts for 50 mS, providing supply was at least 10 V before dropout and supply recovers to 5 Volts. This is achieved without the need for internal batteries.
Max. Current:	Operating 50mA Standby 10mA
Alternator Input Range:	75 Volts (ph-N) to 277 Volts (ph-N) AC (+20%)
Alternator Input Frequency:	50 - 60 Hz at rated engine speed (Minimum: 75V AC Ph-N) (Crank Disconnect from 15V Ph-N @ 20Hz) Overspeed +14% (+24% overshoot) Underspeed -20%
Start Output:	1.2 Amp DC at supply voltage.
Fuel Output:	1.2 Amp DC at supply voltage.
Auxiliary Outputs:	1.2 Amp DC at supply voltage.
Dimensions:	125mm x 165mm x 28 mm
Charge Fail:	12 Volts = 8 Volts CF 24 Volts = 16 Volts CF
Operating Temperature Range:	-30°C to + 70°C
Applicable Standards	Compliant with BS EN 60950 Low Voltage Directive Compliant with BS EN 50081-2: 1992 EMC Directive Compliant with BS EN 61000-6-4: 2000 EMC Directive  Compliance to European Legislation

 Registered Component for USA & Canada

Deep Sea Electronics plc reserve the right to change specification without notice.

6 SOLID STATE OUTPUTS

DSE's utilisation of Solid State Outputs gives many advantages, the main points being:

- ? No Moving Parts
- ? Fully Overload / Short Circuit Protected.
- ? Smaller dimensions hence lighter, thinner and cheaper than conventional relays.
- ? Less power required making them far more reliable.

The main difference from conventional outputs is that solid state outputs switch to negative (-ve) when active. This type of output is normally used with an automotive or plug in relay.

6.1 TYPICAL CONNECTIONS

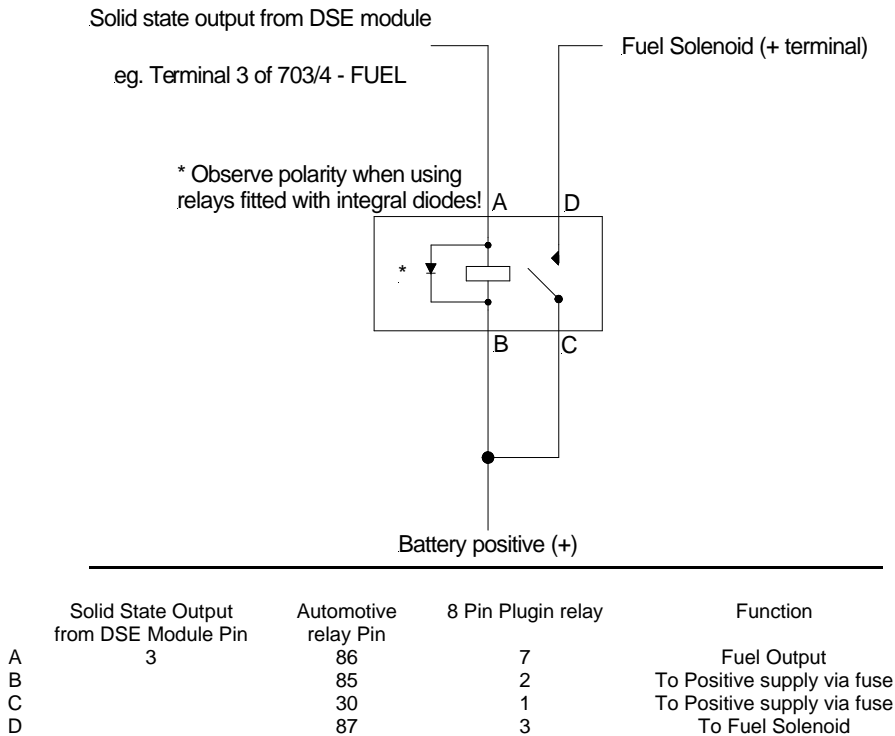

Example of relay pins connected to DSE solid state output to drive a fuel solenoid.
See section on **Typical Connections** else where in this manual for overall typical wiring diagram

7 ADDING A LOAD TRANSFER OUTPUT

The DSE 703 is a very flexible, low cost, remote start module. It can be further enhanced by the addition of simple external wiring to 'convert' the Engine Running output into a Load Transfer output. This allows the 703 module to control a load-switching device, while also giving provision for a Cooling Run.

7.1 CONNECTION DETAILS

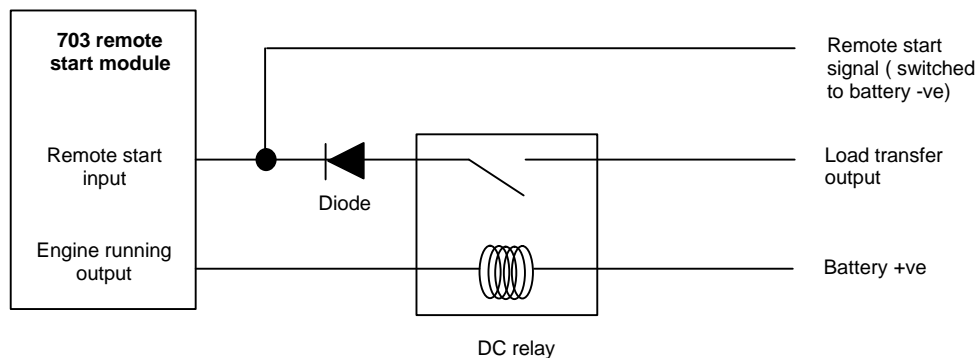

7.2 DESCRIPTION

With the 703 in AUTO mode, applying the remote start signal will begin the start delay timer, after which, the engine will be called upon to start. Upon activation of the Engine Running output, the DC relay will close, switching the remote start signal through its contacts. This switched signal becomes the Load Transfer output, which can be used to drive a DC load-switching device or further slave relay if required.

When the remote start signal is removed, this also removes the Load Transfer output (opening the contractor) and begins the 703's Stop Delay timer. This acts as a cooling timer to allow the set to cool off load. When the Stop Delay timer expires, the set will be stopped.

NOTE:- The diode acts to stop any voltage from the 703's remote start input circuitry being fed through the DC relay.

7.3 CONFIGURATION DETAILS

Auxiliary output 1 Function					Engine running		
†	⚡	⚡	†	⚡	⚡	†	⚡

Stop Delay timer					Timer value	
⚡	⚡	⚡	†	†	Select as required	

Please see the 703 installation instructions for further details of the 703 configuration

8 DIMENSIONS

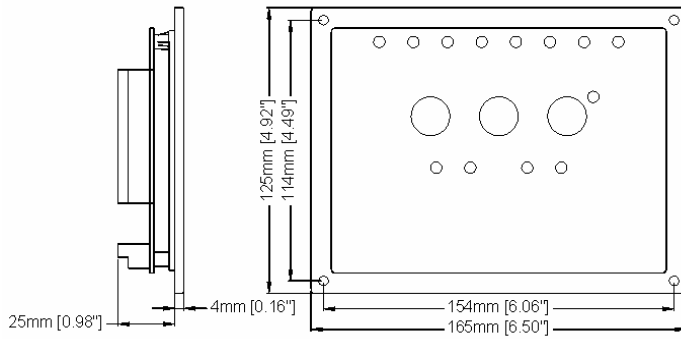

Dimensions:
165mm x 125mm x 29mm
(6.5" x 4.9" x 1.2")

Panel cut out:
149mm x 109mm
(5.9" x 4.3")

Mounting Method:
4 x 4.2mm diameter holes suitable for M4 screws.

9 TYPICAL CONNECTIONS

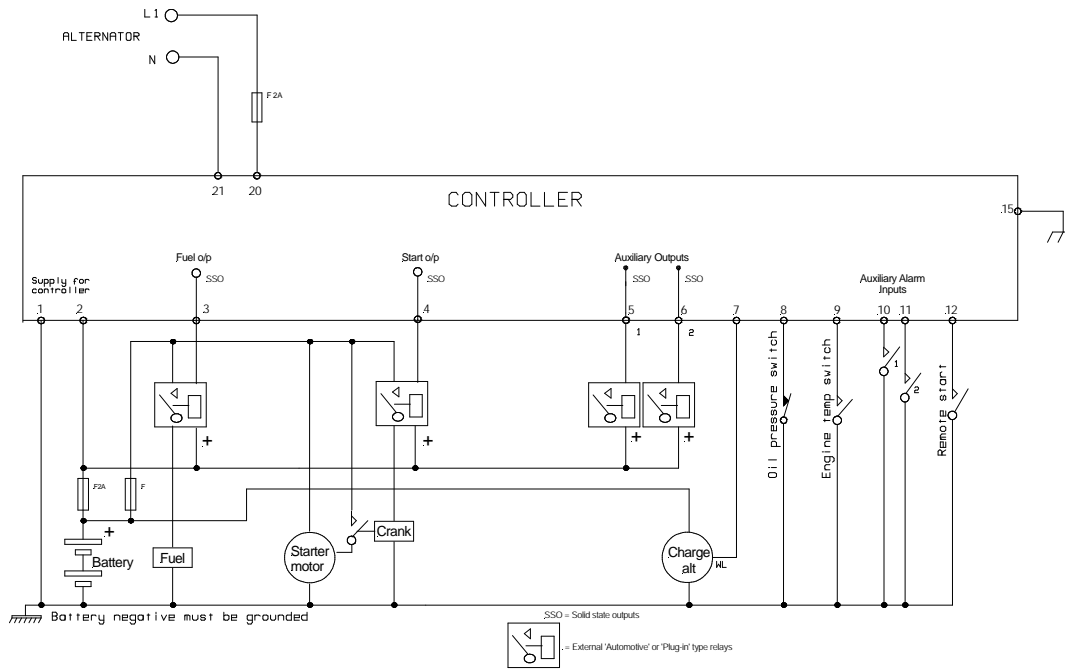

Terminals suitable for 22-16 awg (0.6mm²-1.3mm²) field wiring
Tightening Torque = 0.8N-m (7lb-in)